

# **Tezeko LID-100 Barcode Scanner**

## **USER GUIDE**



## About This User Guide

Pls read all the content of the user guide carefully to use the products safely and effectively. You are advised of keeping it properly for your using reference.

### Disclaimer

Please do not dismantle the product or tear up the seal on it, otherwise we won't provide warranty or replacement service.

The pictures in this user guide are for reference only. If there are any pictures which not match the actual product, please take actual products as the standard. Updated information is subject to change without notice.

All information contained in this guide are protected by copyright, and our company reserves all rights. All or part of this guide is prohibited to excerpt, copy, bundle other products, or sell without the written permission from us.

### Service Information

If you need more technical support, please call or email us, we are happy to serve you.

**Version Record**

Version number	Version description	Version date
Decader AO V7.90	Initial version	2018.5.15

**CATALOG**

1.Product Introduction .....	- 9 -
1.1 Main feature .....	- 9 -
1.2 Unpack your device .....	- 9 -
1.3 Communication port .....	- 9 -
1.4 Interface specification .....	- 10 -
1.4.1 Scanning module interface CMOS .....	- 10 -
1.4.2 Standard serial port (DB9) .....	- 10 -
1.4.3 USB interface .....	- 11 -
1.5 Connection .....	- 11 -
1.5.1 USB cable .....	- 11 -
1.5.2 RS-232 cable .....	- 12 -
1.6 Barcode preset parameters .....	- 12 -
1.7 Start-up, shutdown and restart .....	- 13 -
1.8 Maintenance .....	- 13 -
1.9 Reading skills .....	- 14 -
2.Command specification .....	- 15 -
2.1 Command feedback settings .....	- 15 -
2.2 Sound feedback settings .....	- 15 -
2.3 Trigger command .....	- 15 -
3. System setting .....	- 16 -
3.1 Setting barcode explanation .....	- 16 -

3.2 Use setting barcode .....	- 16 -
3.2.1 Restore Defaults .....	- 16 -
3.2.2 Read BOOTLOAD version .....	- 17 -
3.2.3 USB-KBW mode .....	- 17 -
3.2.4 TTL/RS232 mode .....	- 17 -
3.2.5 Enable/disable setting barcode .....	- 17 -
3.2.6 Send setting barcode .....	- 17 -
3.3 Reading mode .....	- 17 -
3.3.1 Continue reading mode .....	- 18 -
3.3.2 Flashing reading mode .....	- 18 -
3.3.3 Delay single reading mode .....	- 18 -
3.4 Decode sound setting .....	- 19 -
3.4.1 Buzzer Volume setting .....	- 19 -
3.4.2 Beeper frequency .....	- 19 -
3.5 upload speed setting .....	- 19 -
3.6 Inverse code option .....	- 20 -
4. date setting .....	- 20 -
4.1 Code ID setting .....	- 20 -
4.2 User-defined prefix/ suffix .....	- 20 -
4.3 Clear all prefix/ suffix .....	- 21 -
4.4 Hidden character .....	- 21 -
4.4.1 Hide prefix characters .....	- 21 -

4.4.2 Unhide the prefix character .....	- 22 -
4.4.3 Hide suffix characters .....	- 22 -
4.4.4 Unhide the suffix character .....	- 22 -
4.4.5 Hide middle character .....	- 22 -
4.4.6 Hide the middle N character .....	- 24 -
4.4.7 Unhide middle characters .....	- 24 -
4.5 Keyboard layout .....	- 24 -
4.6 Baud rate .....	- 27 -
4.7 Ending character setting .....	- 28 -
4.8 Case conversion .....	- 29 -
5.Symbologies .....	- 30 -
5.1 UPC-A .....	- 30 -
5.1.1 UPC-A .....	- 30 -
5.1.2 UPC-A check bit .....	- 30 -
5.1.3 System character .....	- 30 -
5.1.5 Extended settings .....	- 30 -
5.2 UPC-E .....	- 30 -
5.2.1 UPC-E .....	- 30 -
5.2.2 UPC-E check bit .....	- 31 -
5.2.3 System character .....	- 31 -
5.2.5 Extended settings .....	- 31 -
5.3 EAN-8 .....	- 31 -

5.3.1 EAN-8 .....	- 31 -
5.3.2 EAN-8 check bit .....	- 32 -
5.3.3 System character .....	- 32 -
5.4 EAN-13 .....	- 32 -
5.4.1 EAN-13 .....	- 32 -
5.4.2 EAN-13 check bit .....	- 32 -
5.4.3 Extended settings .....	- 32 -
5.5 Code 128 .....	- 33 -
5.5.1 Code 128 .....	- 33 -
5.6 Code 39 .....	- 33 -
5.6.1 Code 39 .....	- 33 -
5.6.2 ending/start character .....	- 33 -
5.6.3 Code 39 Full ASCII .....	- 34 -
5.7 Code 93 .....	- 34 -
5.7.1 Code 93 .....	- 34 -
5.7.2 Code 93 check bit .....	- 34 -
5.8 Code 11 .....	- 34 -
5.8.1 Code 11 .....	- 34 -
5.8.2 Code 11 check bit .....	- 35 -
5.9 Interleaved 2 of 5 .....	- 35 -
5.9.1 Interleaved 2 of 5 .....	- 35 -
5.10 Matrix 2 of 5 .....	- 35 -

5.11 Industrial 2 of 5 .....	- 35 -
5.12 Standard 2 of 5(IATA) .....	- 36 -
5.13 Codabar (NW-7) .....	- 36 -
5.13.1 Codabar .....	- 36 -
5.13.2 ending/start character .....	- 36 -
5.14 Plessey .....	- 36 -
5.14.1 Plessey .....	- 36 -
5.15 MSI Plessey .....	- 36 -
5.16 GS1 DataBar Limited (RSS Limited) .....	- 37 -
5.17 GS1 DataBar Omnidirectional (RSS Omnidirectional) .....	- 37 -
5.18 China Post (Datalogic 2 of 5) .....	- 37 -
5.19 Additional bit setting .....	- 37 -
Appendix .....	- 39 -
Appendix 1-Code ID .....	- 39 -
Appendix 2-Command table .....	- 40 -
Appendix 3 - Character Table (for adding suffixes and prefix) .....	- 48 -
Appendix 4 - ASCII Code Table .....	- 54 -



## 1.Product Introduction

This user guide applies to M1, which identify 1D barcodes by red light scanning pattern, and apply the complete set of patent technology developed by Guangzhou YOKO Electron Co., Ltd. The scanners above are of strong identification capability, and support automatic continuous scanning mode with fast and flexible scanning speed.

In this chapter, we will introduce the instruction of scanner with pictures, please compare to the scanner you bought when reading this user guide, which is good for your understanding. This chapter applies to regular users, maintenance personnel, and software developers.

### 1.1 Main feature

\* Complete independent research and development, possessing the complete set of patent, plug and play without the need to install driver.

\* Wide voltage design to avoid the data can't be transmitted due to voltage fluctuation.

\* 32-bit master chip equipped with patented software, the scanner can smoothly decode reflective, wrinkled, blurred, and colorful barcode, and can also normally scan in light and dark environment.

\* Adopt all tantalum capacitors and anti-oxidation optical technology, avoiding the problem of sensitivity declining after long-term using.

### 1.2 Unpack your device

After you open the shipping carton containing the product, take the following steps:

- Take out the accessories from package.
- Check with the packing list to see if everything is complete and in good condition.
- If there are any damaged or missing components, please keep the original package and contact your supplier for after-sales service.

### 1.3 Communication port

The product must be connected with a host before it can be operated and used. The host can be a PC, a POS machine or a smart terminal with a USB interface.

**USB**

USB interface on the host



**RS-232**

RS-232 interface on the host



## 1.4 Interface specification

Product standard interfaces include: RS232 (DB9)、USB Keyboard. The standard interfaces of different products are different. Please confirm before purchase. Other interfaces can be customized according to customer requirements.

### 1.4.1 Scanning module interface CMOS

PIN	Name	Type	Specification
1	NC	null	backup
2	VCC	DC power	Dc3.3v or DC5V (according to different modules) $\pm$ 5%
3	GND	Ground	GND
4	Rx	Input	TTL level of serial input port
5	Tx	Output	TTL level of serial output port
6	USB_D-	I / O	USB_D- signal
7	USB_D+	I / O	USB_D+ signal
8	NC	null	backup
9	BPR	Output	Buzzer output signal.
10	LED	Output	The indicator light prompts that the decoding is successful and the output low level is 150ms
11	NC	null	backup
12	TRIG	Input	Trigger scan

### 1.4.2 Standard serial port (DB9)

PIN	Function
1	Trigger(Optional)
2	Rx
3	Tx
5	GND
9	DC 5V(Optional)

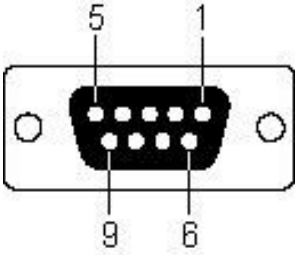

At pin 1 of the serial port, when the pin receives the low level for 10ms, it is equivalent to pressing the trigger button to trigger scanning (this function is optional).

In the serial port, pin 6 is only used for trigger mode. If no barcode is recognized after each trigger scanning, the pin will output low level 100ms (this function belongs to value-added service).

### 1.4.3 USB interface

No.	Function
1	VCC
2	D-
3	D+
4	GND

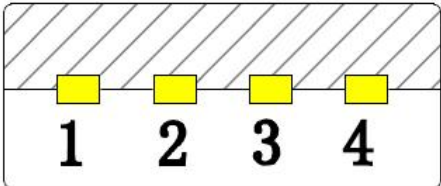

According to the actual situation, it can be divided into two kinds: USB HID keyboard and USB virtual serial port. When you connect the engine to the host via USB, you can enable the USB hid-kbw feature by scanning the barcode below; then the transmission of the engine will be simulated as USB keyboard input. The host receives a key from the virtual keyboard. It's a plug and play foundation

## 1.5 Connection

### 1.5.1 USB cable

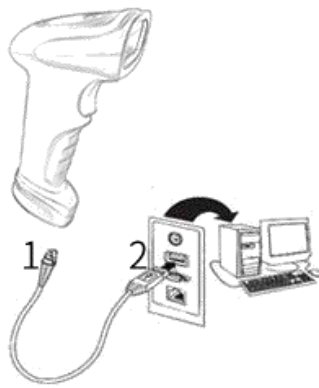

- 1: Connect the device interface end of USB data line with the product;
- 2: Connect the host interface (USB interface) of USB data cable to the host.

## 1.5.2 RS-232 cable

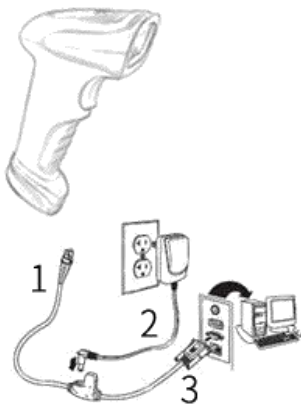

- 1: Connect the equipment interface end of RS-232 data line with the product;
- 2: Connect RS-232 data line with power adapter;
- 3: Connect the host interface end (RS-232 interface) of RS-232 data line to the host.

## 1.6 Barcode preset parameters

Symbologies	read	check	transmission	Suffix/ Prefix	Min length	Max length	CODE ID
EAN13	√	√	√	X	13		d
EAN8	√	√	√	X	8		c
UPC A	√	√	√	X	12		e
UPC E	√	√	√	X	8		f
UPC/EAN 2Add-on	X	X	X	X			
UPC/EAN 5Add-on	X	X	X	X			
ISBN	-	√	√	X	8	60	d
ISSN	-	√	√	X	8	60	d
CODABAR (NW-7)	√	X	X	-	4	60	v
CODE 39	√	X	X	-	2	40	m
CODE 93	√	√	-	X	1	80	i

INTERLEAVED 2OF5 <sup>n</sup>	√	X	X	X	4	80	n
Industrial 2 of 5	√	X	X	X	3	80	o
Standard 2 of 5	X	X	X	X	7	80	p
GS1-128	√	X	X	X	3	60	a
MATRIX 2OF5	√	X	X	X	3	80	q
CODE 128	√	√	-	X	1	80	a
Code 32	-	X	X	X	9	80	m
CODE 11	√	√	√	X	4	80	u
Pleesy	X	X	X	X	4	50	t
MSI Pleesy	-	X	X	X	5	50	s
GS1 DataBar Limited	X	X	X	X	15	60	k
GSI Databar Omnidirectional	-	X	X	X	15	60	j
China Post	-	X	X	X	7	80	r
All Symbologies							@

**Note:**

1. "√" indicates that the default parameter is on, "-" indicates that the default parameter is off, "x" indicates that the parameter does not exist in the barcode type;
2. Mark "2" in the upper right corner of the minimum / large length to indicate that the bar code length is fixed;
3. The barcode type marked with "n" in the upper right corner of barcode type supports inverse decoding (white bar on black background).

**1.7 Start-up, shutdown and restart**

**Start-up:** Connect host computer with scanner, which will automatically start-up and in working state.

**Shutdown:** Remove the data cable which is connected with scanner; remove the USB which is connected with host computer.

**Restart:** If the scanner crashes or doesn't respond, please switch it off and restart.

**1.8 Maintenance**

\* The window must be kept clean, the supplier do not bear the guarantee responsibility due

to the improper maintenance.

- \* Avoid the window being wear and tear or scratched by hard object
- \* Use the hairbrush to remove the stain on the window
- \* Clean the window with a soft cloth, such as lens cleaning cloth
- \* Spraying liquid onto the window is prohibited.
- \* Prohibit any cleaning solvents, except for the cleaning water.

#### 1.9 Reading skills

If the barcode is small, it should be closer to the scanning window; if the barcode is large, it should be far away from the scanning window a little more, thus easier to be read correctly.

If the barcode is highly reflective (for example, the coated surface), you may need to tilt the barcode at an angle to successfully scan it.

#### **Barcode scanning example:**



## 2.Command specification

### 2.1 Command feedback settings

When the setup response is enabled (scan the setup code 02421, or the serial port send command is enabled), if the setup command is successfully executed, an answer character ack (ASCII code is 0x06) will be answered. If it is not successfully executed, a NAK (ASCII code is 0x15) will be answered.



02421

Enable response

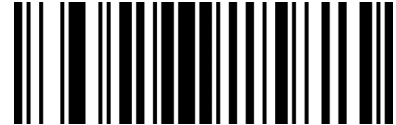

02420

Disable response (default)

### 2.2 Sound feedback settings

When the sound feedback is turned on (scan the setting code 01411, or send the serial port command to turn on), if the setting command is executed successfully, the buzzer will sound once, and the command execution sound feedback is turned off by default.

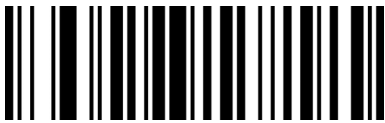

01411

Enable sound feedback



01410

Disable sound feedback (default)

### 2.3 Trigger command

Enable scan: 02 01 01 02 B8 0B 00 00 00 00 00 00 00 00 03 34

Disable scan: 02 01 01 00 00 00 00 00 00 00 00 00 00 00 03 F9

### 3. System setting

Option and function setting mainly through reading a series of special barcodes. In this chapter, we will provide you a detailed introduction of the options and functions available for user setting, and the corresponding setup code.

This method of setting the scanning is direct, easy to understand and user friendly.

#### 3.1 Setting barcode explanation



#### 3.2 Use setting barcode

All barcode scanners have a factory default setting. Reading the “Restore Defaults” barcode scanners will restore all the property settings of the bar code to the factory state.

You are most likely to use this barcode in the following situations:

1. The barcode scanner setting error occurs, if the barcode is not recognized.
2. You forgot what settings you have made to the barcode before, but you don't want to use the previous settings.
3. After setting up the barcode scanner to use some of the functions that are not commonly used.

##### 3.2.1 Restore Defaults



000B0

Restore Defaults



**3.2.2 Read BOOTLOAD version**

000A0

Read BOOTLOAD version

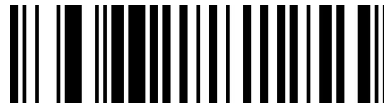
**3.2.3 USB-KBW mode**

000602 USB-KBW mode (default)

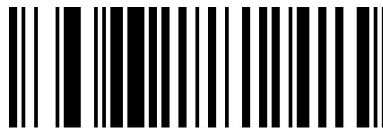
**3.2.4 TTL/RS232 mode**

000601 TTL/RS232

**3.2.5 Enable/disable setting barcode**09990 enable setting  
barcode (default)09991 disable  
setting barcode**3.2.6 Send setting barcode**02501 enable sending  
setting barcode02500 disable sending  
setting barcode (default)**3.3 Reading mode**



013300 Manual reading mode (default)

### 3.3.1 Continue reading mode



013304 Continue reading mode

### 3.3.2 Flashing reading mode



013306

Flashing reading mode  
(button on)



013305

Flashing reading mode  
(button off)

### 3.3.3 Delay single reading mode

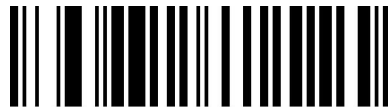

013301 delay single reading mode



023510 delay 1s



023530 delay 3s (default)



0235A0 delay 10s



0235F0 delay 15s

### 3.4 Decode sound setting



014201 enable good-read beep

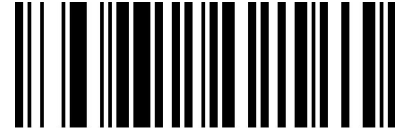

014200 disable good-read beep

#### 3.4.1 Buzzer Volume setting

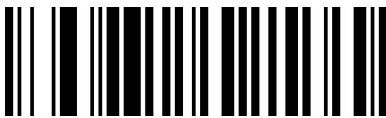

014300 Volume high



014301 Volume low

#### 3.4.2 Beeper frequency



0145800 2.0KHZ (default)



0145AAA 2.7KHZ

### 3.5 upload speed setting

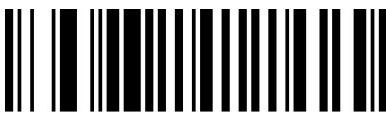

001500 upload speed fast



001502 upload speed middle (default)



001504 upload speed slow

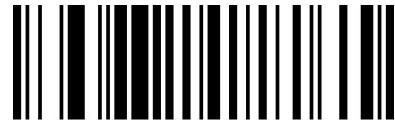

001506 upload speed slowest

### 3.6 Inverse code option

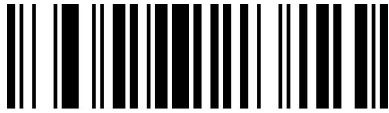

00161 Normal barcode reading (default)

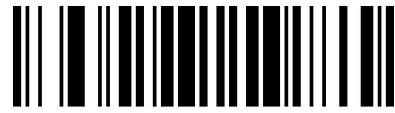

00160 Inverse code reading

## 4. date setting

### 4.1 Code ID setting

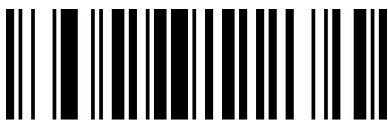

01401 enable sending CODE ID



01400 disable sending Code ID (default)

### 4.2 User-defined prefix/ suffix



02240 user-defined prefix



02241 user-defined suffix

### 4.3 Clear all prefix/ suffix



02220 clear all prefix



02200 clear all suffix

#### 4.3.1 Exit setting prefix and suffix

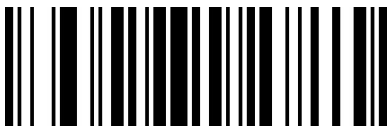
02242 Exit setting  
prefix and suffix

### 4.4 Hidden character

#### 4.4.1 Hide prefix characters

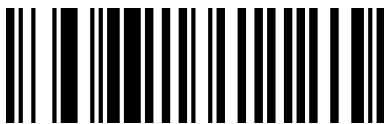
023401 Hide prefix 1  
character023402 Hide prefix 2  
characters



023403 Hide prefix 3 characters



023405 Hide prefix 5 characters

#### 4.4.2 Unhide the prefix character

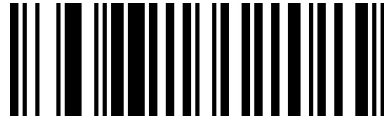

023400 Unhide the prefix character

#### 4.4.3 Hide suffix characters

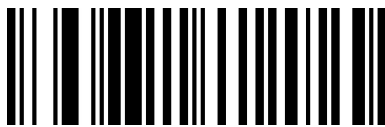

023301 Hide suffix 1 character

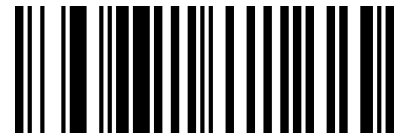

023302 Hide suffix 2 characters



023303 Hide suffix 3 characters



023305 Hide suffix 5 characters

#### 4.4.4 Unhide the suffix character

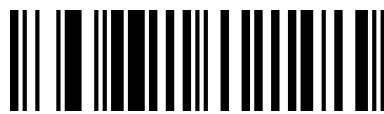

023300 Unhide the suffix character

#### 4.4.5 Hide middle character



024001 The first character begins



024002 The second character begins



024003 The 3rd character begins



024004 The 4th character begins



024005 The 5th character begins



024006 The 6th character begins



024007 The 7th character begins



024008 the 8th character begins



023901 Hide the middle 1 character

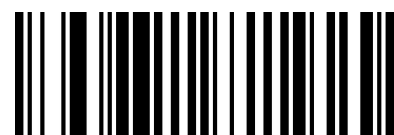

023902 Hide the middle 2 characters

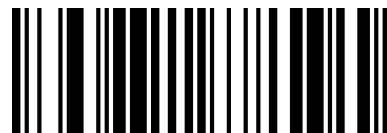

023903 Hide the middle 3 characters



023904 Hide the middle 4 characters



023905 Hide the middle 5 characters

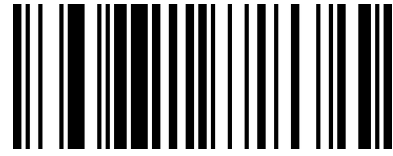

023906 Hide the middle 6 characters

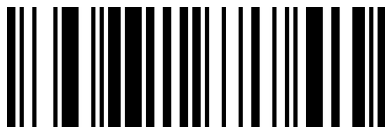

023907 Hide the middle 7 characters

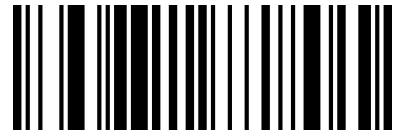

023908 Hide the middle 8 characters

#### 4.4.6 Hide the middle N character

NOTE: Temporarily unavailable

#### 4.4.7 Unhide middle characters

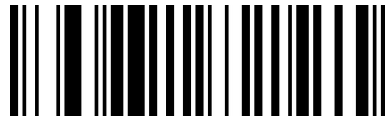

023900 Unhide middle characters

### 4.5 Keyboard layout



0005000 American (default)



0005001 Canada (French)





0005002 Netherlands (Dutch)



0005003 Spain (Spanish-International)



0005004 Argentina (Latin American)



0005005 Brazil (Portuguese)



0005006 Denmark (Danish)



0005007 British (British English)



0005008 Italian 142 (Italy)



0005009 France (French)



0005010 Germany (slang)



0005011 Norway (Northern Sami)



0005012 Sweden/Finland (Swedish/Finnish)



0005013 Slovakia (Slovak)



0005014 Portugal (Portuguese)

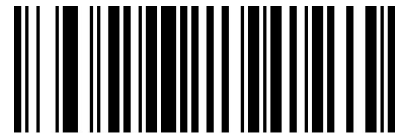

0005015 Czech Republic (Czech)



0005016 Belgium (Dutch, French)



0005017 Turkish-F



0005018 Turkish-Q



0005019 Poland (Polish 214)



0005020 Italian (Switzerland)



0005021 Croatia (Croatian)



0005022 Hungary (Hungarian)



0005023 Japan (Japanese)



0005024 Russian (MS)

#### 4.6 Baud rate

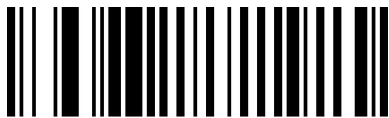

000702 1200bps

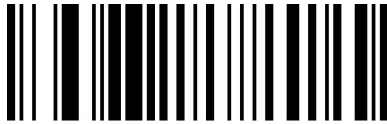

000703 2400bps



000704 4800bps



000705 9600bps (default)



000706 19200bps

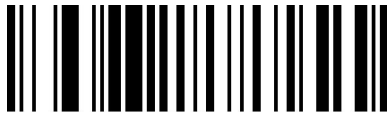

000707 38400bps

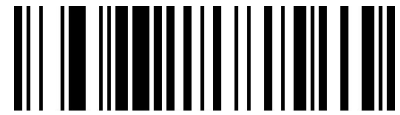

000708 57600bps

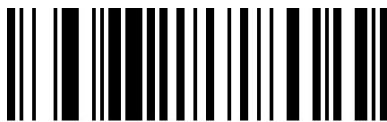

000709 115200bps

#### 4.7 Ending character setting



0212@0D CR (default)



0212@0A LF



0213@0D0A CRLF



0212@09 Tab



0210@ NULL

#### 4.8 Case conversion



02510  
Normal (default)



02511  
Upper



02512  
Lower



02513  
Inverse

## 5.Symbologies

### 5.1 UPC-A

#### 5.1.1 UPC-A

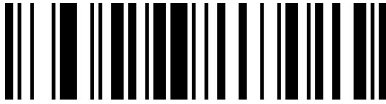

000351

Enable UPC-A (default)



000350

Disable UPC-A

#### 5.1.2 UPC-A check bit

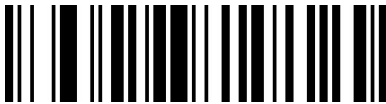

00521

Send UPC-A check bit (default)



00520

Don't send UPC-A check bit

#### 5.1.3 System character



00500

Send system character (default)

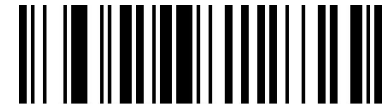

00501

Don't send system character

#### 5.1.5 Extended settings



00391

Enable UPC-A to EAN-13

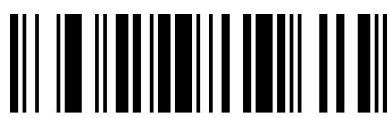

00390

Disable UPC-A to EAN-13 (default))

### 5.2 UPC-E

#### 5.2.1 UPC-E



00351

Enable UPC-E (default)



00350

Disable UPC-E

### 5.2.2 UPC-E check bit

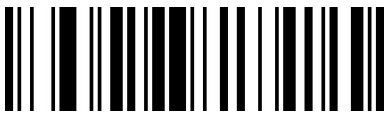

00551

Send UPC-E check bit (default)



00550

Don't send UPC-E check bit

### 5.2.3 System character

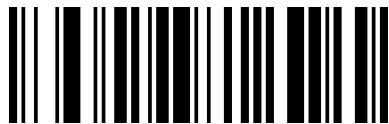

00530

Send system character (default)

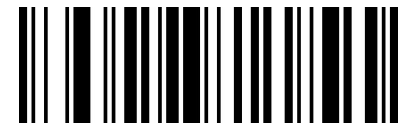

00531

Don't send system character

### 5.2.5 Extended settings



00381

Enable UPC-E to UPC-A



00380

Disable UPC-E to UPC-A (default)

## 5.3 EAN-8

### 5.3.1 EAN-8

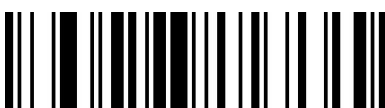

00371

Enable EAN-8 (default)



00370

Disable EAN-8

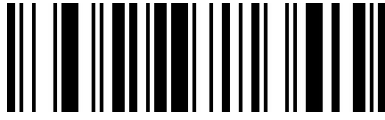
**5.3.2 EAN-8 check bit**

00571

Send EAN-8 check bit (default)

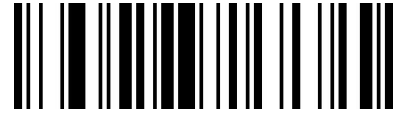

00570

Don't send EAN-8 check bit

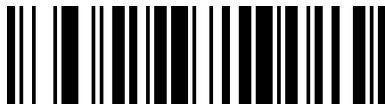
**5.3.3 System character**

00560

Send system character (default)

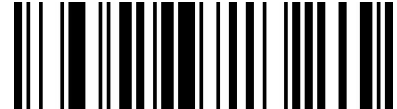

00561

Don't send system character

**5.4 EAN-13****5.4.1 EAN-13**

00361

Enable EAN-13 (default)

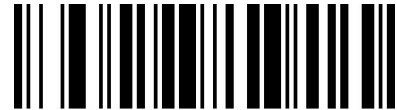

00360

Disable EAN-13

**5.4.2 EAN-13 check bit**

00561

Send EAN-13 check bit (default)



00560

Don't send EAN-13 check bit

**5.4.3 Extended settings**

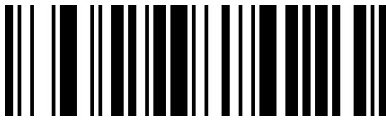

**00581**

Enable EAN13 to ISBN

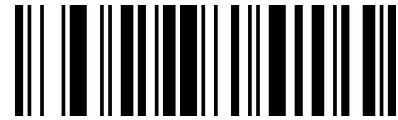
**00580**

Disable EAN13 to ISBN (default)

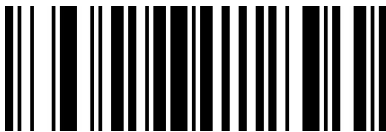
**01501**

Enable EAN13 to ISSN

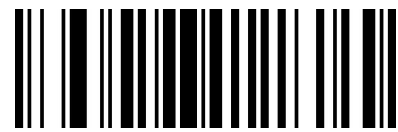
**01500**

Disable EAN13 to ISSN (default)

**5.5 Code 128**

## 5.5.1 Code 128

**00691**

Enable Code 128 (default)

**00690**

Disable Code 128

**5.6 Code 39**

## 5.6.1 Code 39

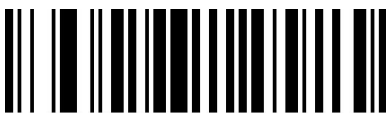
**00221**

Enable Code 39 (default)

**00220**

Disable Code 39

## 5.6.2 ending/start character

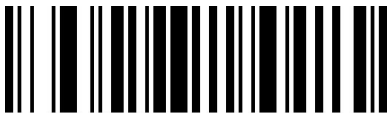

00281

Send ending/start character



00280

Don't send ending/start character (default)

## 5.6.3 Code 39 Full ASCII

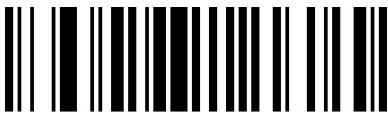

00231

Enable Full ASCII\*

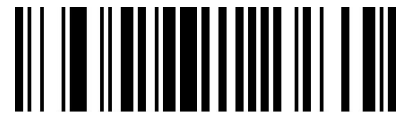

00230

Disable Full ASCII

## 5.7 Code 93

### 5.7.1 Code 93



00621

Enable Code 93 (default)

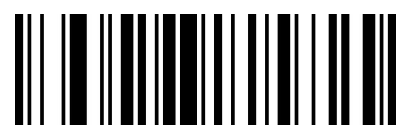

00620

Disable Code 93

### 5.7.2 Code 93 check bit



01901

Send code 93 check bit

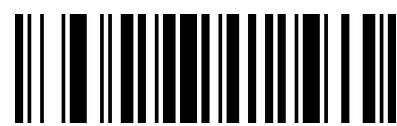

01900

Don't send code 93 check bit (default)

## 5.8 Code 11

### 5.8.1 Code 11



01261

Enable Code 11 (default)

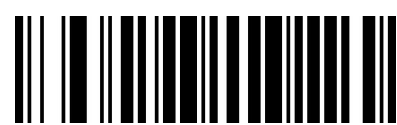

01260

Disable Code 11

**5.8.2 Code 11 check bit**

01272 C check (default)



01273 CK check

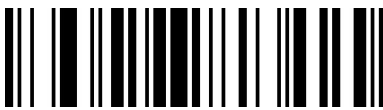

01271 Automatic CK check

**5.9 Interleaved 2 of 5****5.9.1 Interleaved 2 of 5**

00961 Enable Interleaved 2 of 5 (default)

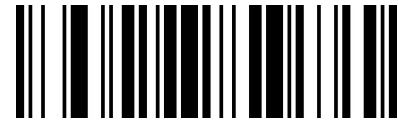

00960 Disable Interleaved 2 of 5

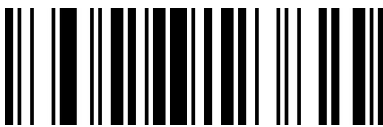
**5.10 Matrix 2 of 5**

01561

Enable Matrix 2 of 5 (default)



01560

Disable Matrix 2 of 5

**5.11 Industrial 2 of 5**

01061

Enable Industrial 2 of 5 (default)



01060

Disable Industrial 2 of 5

**5.12 Standard 2 of 5(IATA)**

01871

Enable Standard 2 of 5 (default)



01870

Disable Standard 2 of 5

**5.13 Codabar (NW-7)**

## 5.13.1 Codabar

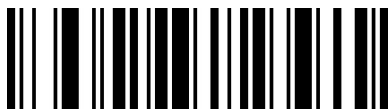

00851

Enable Codabar (default)

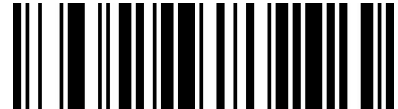

00850

Disable Codabar

## 5.13.2 ending/start character



00861

Send ending/start character

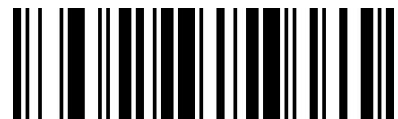

00860

Don't send ending/start character (default)

**5.14 Plessey**

## 5.14.1 Plessey



01161

Enable Plessey



01160

Disable Plessey (default)

**5.15 MSI Plessey**



01151

Enable MSI Plessey



01150

Disable MSI Plessey (default)

**5.16 GS1 DataBar Limited (RSS Limited)**

## 5.15.1 RSS Limited



01771

Enable RSS Limited



01770

Disable RSS Limited (default)

**5.17 GS1 DataBar Omnidirectional (RSS Omnidirectional)**

01671

Enable RSS Omnidirectional



01670

Disable RSS Omnidirectional (default)

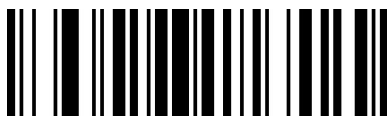
**5.18 China Post (Datalogic 2 of 5)**

01571

Enable China Post



01570

Disable China Post\*

**5.19 Additional bit setting**

00551 Enable 2 additional bits



00552 Enable 5 additional bits

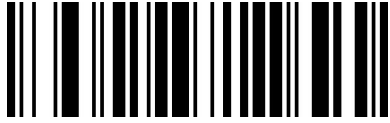

00553 Enable 2 and 5 additional bits

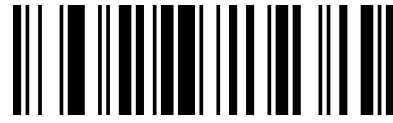

00550 Disable additional bits (default)



02611 Forced to include additional bits

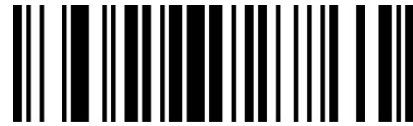

02610 Do not force include additional bits  
(default)

## Appendix

### Appendix 1-Code ID

SN	Symbologies	Code ID	Barcode type code (used by prefix and suffix)
1	All Symbologies	@	00
2	CODE 128	a	01
3	EAN 8	c	03
4	EAN 13	d	04
5	UPC-A	e	05
6	UPC-E	zz f	06
7	CODE 93	i	09
8	GS1 Omnidirectional	j	0A
9	GS1 Limited	k	0B
10	CODE 39	m	0D
11	Interleaved 2 of 5	n	0E
12	Industrial 2 of 5	o	0F
13	Standard 2 of 5	p	10
14	Matrix 2 of 5	q	11
15	China Post	r	12
16	MSI	s	13
17	Plessey	t	14
18	Code 11	u	15
19	Codabar	v	16

**Appendix 2-Command table**

Function	Command	Hex command
1. Enable no delay scan	NA	02 01 01 01 00 00 00 00 00 00 00 00 00 03 F8
2. Enable delay 3s scan	NA	02 01 01 02 B8 0B 00 00 00 00 00 00 00 03 34
3. Enable delay 10s scan	NA	02 01 01 02 10 27 00 00 00 00 00 00 00 03 C0
4. Disable scan	NA	02 01 01 00 00 00 00 00 00 00 00 00 00 03 F9
5. Restore Defaults	000B0	02 02 06 82 30 30 30 42 30 00 00 00 00 03 6F
6. Read BOOTLOAD version	000A0	02 02 06 82 30 30 30 41 30 00 00 00 00 03 70
7. Enable setting barcode	09990	02 02 06 82 30 39 39 39 30 00 00 00 00 03 66
8. Disable setting barcode	09991	02 02 06 82 30 39 39 39 31 00 00 00 00 03 65
9. Enable sending setting barcode	02501	02 02 06 82 30 32 35 30 31 00 00 00 00 03 79
10. Disable sending setting barcode	02500	02 02 06 82 30 32 35 30 30 00 00 00 00 03 7A
11. Manual reading mode	013300	02 02 07 82 30 31 33 33 30 30 00 00 00 03 49
12. Continue reading mode	013304	02 02 07 82 30 31 33 33 30 34 00 00 00 03 45
13. Enable auto sense	02311	02 02 06 82 30 32 33 31 31 00 00 00 00 03 7A
14. Disable auto sense	02310	02 02 06 82 30 32 33 31 30 00 00 00 00 03 7B
15. Flashing reading mode (button on)	013306	02 02 07 82 30 31 33 33 30 36 00 00 00 03 43
16. Flashing reading mode (button off)	013305	02 02 07 82 30 31 33 33 30 35 00 00 00 03 44
17. Delay single reading mode	013301	02 02 07 82 30 31 33 33 30 31 00 00 00 03 48
18. Delay 1s	023510	02 02 07 82 30 32 33 35 31 30 00 00 00 03 45
19. Delay 3s	023530	02 02 07 82 30 32 33 35 33 30 00 00 00 03 43
20. Delay 10s	0235A0	02 02 07 82 30 32 33 35 41 30 00 00 00 03 35
21. Delay 15s	0235F0	02 02 07 82 30 32 33 35 46 30 00 00 00 03 30



22. Enable good-read beep	014201	02 02 07 82 30 31 34 32 30 31 00 00 00 00 03 48
23. Disable good-read beep	014200	02 02 07 82 30 31 34 32 30 30 00 00 00 00 03 49
24. <b>Volume higher</b>	014300	02 02 07 82 30 31 34 33 30 30 00 00 00 00 03 48
25. <b>Volume lower</b>	014301	02 02 07 82 30 31 34 33 30 31 00 00 00 00 03 47
26. Beeper frequency 2.0KHZ	014580 0	02 02 08 82 30 31 34 35 38 30 30 00 00 00 03 0D
27. Beeper frequency 2.7KHZ	0145AA A	02 02 08 82 30 31 34 35 41 41 41 00 00 00 03 E2
28. Enable USB fast upload	02301	02 02 06 82 30 32 33 30 31 00 00 00 00 00 03 7B
29. Disable USB fast upload	02300	02 02 06 82 30 32 33 30 30 00 00 00 00 00 03 7C
30. Upload speed fast	001500	02 02 07 82 30 30 31 35 30 30 00 00 00 00 03 4A
31. Upload speed middle	001502	02 02 07 82 30 30 31 35 30 32 00 00 00 00 03 48
32. Upload speed slow	001504	02 02 07 82 30 30 31 35 30 34 00 00 00 00 03 46
33. Upload speed slowest	001506	02 02 07 82 30 30 31 35 30 36 00 00 00 00 03 44
34. Normal barcode reading	00161	02 02 06 82 30 30 31 36 31 00 00 00 00 00 03 79
35. Inverse code reading	024B00 2.	02 02 06 82 30 30 31 36 30 00 00 00 00 00 03 7A
36. USB-KBW	000602	02 02 07 82 30 30 30 36 30 32 00 00 00 00 03 48
37. PS2	000600	02 02 07 82 30 30 30 36 30 30 00 00 00 00 03 4A
38. USB-COM	000603	02 02 07 82 30 30 30 36 30 33 00 00 00 00 03 47
39. TTL/RS232	000601	02 02 07 82 30 30 30 36 30 31 00 00 00 00 03 49
40. Baud rate600bps	000701	02 02 07 82 30 30 30 37 30 31 00 00 00 00 03 48
41. Baud rate1200bps	000702	02 02 07 82 30 30 30 37 30 32 00 00 00 00 03 47
42. Baud rate2400bps	000703	02 02 07 82 30 30 30 37 30 33 00 00 00 00 03 46
43. Baud rate4800bps	000704	02 02 07 82 30 30 30 37 30 34 00 00 00 00 03 45
44. Baud rate9600bps	000705	02 02 07 82 30 30 30 37 30 35 00 00 00 00 03 44
45. Baud rate19200bps	000706	02 02 07 82 30 30 30 37 30 36 00 00 00 00 03 43
46. Baud rate38400bps	000707	02 02 07 82 30 30 30 37 30 37 00 00 00 00 03 42
47. Baud rate57600bps	000708	02 02 07 82 30 30 30 37 30 38 00 00 00 00 03 41
48. Baud rate115200bps	000709	02 02 07 82 30 30 30 37 30 39 00 00 00 00 03 40
49. Enable sending CODE ID	01401	02 02 06 82 30 31 34 30 31 00 00 00 00 00 03 7B

50. Disable sending CODE ID	01400	02 02 06 82 30 31 34 30 30 00 00 00 00 03 7C
51. User-defined prefix	0223XX	XX is the hexadecimal code of the corresponding character of "appendix character table". One can be added at a time and can be added cumulatively. Example: add character A (0x41), set code to 022341, and command to: 02 02 07 82 30 32 32 33 34 31 00 00 00 03 44
52. Clear all prefix	02220	02 02 06 82 30 32 32 32 30 00 00 00 00 03 7B
53. User-defined suffix	0221XX	XX is the hexadecimal code of the corresponding character of "appendix character table". One can be added at a time and can be added cumulatively. Example: add character B (0x42), set code to 022341, and command to: 02 02 07 82 30 32 32 31 34 32 00 00 00 03 45
54. Clear all suffix	02200	02 02 06 82 30 32 32 30 30 00 00 00 00 03 7D
55. Hide prefix 1 character	023401	02 02 07 82 30 32 33 34 30 31 00 00 00 03 46
56. Hide prefix 2 characters	023402	02 02 07 82 30 32 33 34 30 32 00 00 00 03 45
57. Hide prefix 3 characters	023403	02 02 07 82 30 32 33 34 30 33 00 00 00 03 44
58. Hide prefix 5 characters	023405	02 02 07 82 30 32 33 34 30 33 00 00 00 03 44
59. Unhide the prefix character	023400	02 02 07 82 30 32 33 34 30 30 00 00 00 03 47
60. Hide suffix 1 character	023301	02 02 07 82 30 32 33 33 30 31 00 00 00 03 47
61. Hide suffix 2 characters	023302	02 02 07 82 30 32 33 33 30 32 00 00 00 03 46
62. Hide suffix 3 characters	023303	02 02 07 82 30 32 33 33 30 33 00 00 00 03 45
63. Hide suffix 5 characters	023305	02 02 07 82 30 32 33 33 30 35 00 00 00 03 43
64. Unhide the suffix character	023300	02 02 07 82 30 32 33 33 30 30 00 00 00 03 48
65. The first character begins	024001	02 02 07 82 30 32 34 30 30 31 00 00 00 03 49
66. The 2nd character begins	024002	02 02 07 82 30 32 34 30 30 32 00 00 00 03 48
67. The 3rd character begins	024003	02 02 07 82 30 32 34 30 30 33 00 00 00 03 47
68. The 4th character begins	024004	02 02 07 82 30 32 34 30 30 34 00 00 00 03 46
69. The 5th character begins	024005	02 02 07 82 30 32 34 30 30 35 00 00 00 03 45
70. The 6th character begins	024006	02 02 07 82 30 32 34 30 30 36 00 00 00 03 44
71. The 7th character begins	024007	02 02 07 82 30 32 34 30 30 37 00 00 00 03 43
72. The 8th character begins	024008	02 02 07 82 30 32 34 30 30 38 00 00 00 03 42

73. Hide the middle 1 character	023901	02 02 07 82 30 32 33 39 30 31 00 00 00 00 03 41
74. Hide the middle 2 characters	023902	02 02 07 82 30 32 33 39 30 32 00 00 00 00 03 40
75. Hide the middle 3 characters	023903	02 02 07 82 30 32 33 39 30 33 00 00 00 00 03 3F
76. Hide the middle 4 characters	023904	02 02 07 82 30 32 33 39 30 34 00 00 00 00 03 3E
77. Hide the middle 5 characters	023905	02 02 07 82 30 32 33 39 30 35 00 00 00 00 03 3D
78. Hide the middle 6 characters	023906	02 02 07 82 30 32 33 39 30 36 00 00 00 00 03 3C
79. Hide the middle 7 characters	023907	02 02 07 82 30 32 33 39 30 37 00 00 00 00 03 3B
80. Hide the middle 8 characters	023908	02 02 07 82 30 32 33 39 30 38 00 00 00 00 03 3A
81. Unhide middle characters	023300	02 02 07 82 30 32 33 39 30 30 00 00 00 00 03 42
82. Add <CR>	0212@« CR»	02 02 07 82 30 32 31 32 40 0D 00 00 00 00 03 5E
83. Add <LF>	0212@« LF»	02 02 07 82 30 32 31 32 40 0A 00 00 00 00 03 61
84. Add<CR><LF>	0213@« CR»«LF »	02 02 08 82 30 32 31 33 40 0D 0A 00 00 00 03 52
85. Add TAB	0122@« HT»	02 02 07 82 30 32 31 32 40 09 00 00 00 00 03 62
86. Nor suffix	0210@	02 02 06 82 30 32 31 30 40 00 00 00 00 00 03 6E
87. Case conversion-Normal	02510	02 02 06 82 30 32 35 31 30 00 00 00 00 00 03 79
88. Case conversion-Upper	02511	02 02 06 82 30 32 35 31 31 00 00 00 00 00 03 78
89. Case conversion-Lower	02512	02 02 06 82 30 32 35 31 32 00 00 00 00 00 03 77
90. Case conversion-Inverse	02513	02 02 06 82 30 32 35 31 33 00 00 00 00 00 03 76
91. Enable UPC-A	000341	02 02 07 82 30 30 30 33 34 31 00 00 00 00 03 48
92. Disable UPC-A	000340	02 02 07 82 30 30 30 33 34 30 00 00 00 00 03 49
93. UPC-A send check bit	00421	02 02 06 82 30 30 34 32 31 00 00 00 00 00 03 7A
94. UPC-A don't send check bit	00420	02 02 06 82 30 30 34 32 30 00 00 00 00 00 03 7B
95. UPC-A send system bit	00400	02 02 06 82 30 30 34 30 30 00 00 00 00 00 03 7D
96. UPC-A don't send system bit	00401	02 02 06 82 30 30 34 30 31 00 00 00 00 00 03 7C

97. UPC-A expand	00391	02 02 06 82 30 30 33 39 31 00 00 00 00 00 03 74
98. UPC-A don't expand	00390	02 02 06 82 30 30 33 39 30 00 00 00 00 00 03 75
99. Enable UPC-E	00351	02 02 06 82 30 30 33 35 31 00 00 00 00 00 03 78
100. Disable UPC-E	00350	02 02 06 82 30 30 33 35 30 00 00 00 00 00 03 79
101. UPC-E send check bit	00441	02 02 06 82 30 30 34 34 31 00 00 00 00 00 03 78
102. UPC-E don't send check bit	00440	02 02 06 82 30 30 34 34 30 00 00 00 00 00 03 79
103. UPC-E send system bit	00430	02 02 06 82 30 30 34 33 30 00 00 00 00 00 03 7A
104. UPC-E don't send system bit	00431	02 02 06 82 30 30 34 33 31 00 00 00 00 00 03 79
105. UPC-E expand	00381	02 02 06 82 30 30 33 38 31 00 00 00 00 00 03 75
106. UPC-E don't expand	00380	02 02 06 82 30 30 33 38 30 00 00 00 00 00 03 76
107. Enable EAN-8	00371	02 02 06 82 30 30 33 37 31 00 00 00 00 00 03 76
108. Disable EAN-8	00370	02 02 06 82 30 30 33 37 30 00 00 00 00 00 03 77
109. EAN-8 send check bit	00571	02 02 06 82 30 30 35 37 31 00 00 00 00 00 03 74
110. EAN-8 don't send check bit	00570	02 02 06 82 30 30 35 37 30 00 00 00 00 00 03 75
111. EAN-8 send system bit	00560	02 02 06 82 30 30 35 36 30 00 00 00 00 00 03 76
112. EAN-8 don't send system bit	00561	02 02 06 82 30 30 35 36 31 00 00 00 00 00 03 75
113. Enable EAN-13	00361	02 02 06 82 30 30 33 36 31 00 00 00 00 00 03 77
114. Disable EAN-13	00360	02 02 06 82 30 30 33 36 30 00 00 00 00 00 03 78
115. EAN-13 send check bit	00461	02 02 06 82 30 30 34 36 31 00 00 00 00 00 03 76
116. EAN-13 don't send check bit	00460	02 02 06 82 30 30 34 36 30 00 00 00 00 00 03 77
117. EAN-13 expand ISBN	00481	02 02 06 82 30 30 34 38 31 00 00 00 00 00 03 74
118. EAN-13 don't expand ISBN	00480	02 02 06 82 30 30 34 38 30 00 00 00 00 00 03 75
119. EAN-13 expand ISSN	01501	02 02 06 82 30 31 35 30 31 00 00 00 00 00 03 7A

120.	EAN-13 don't expand ISSN	01500	02 02 06 82 30 31 35 30 30 00 00 00 00 03 7B
121.	Enable Code 128	00691	02 02 06 82 30 30 36 39 31 00 00 00 00 03 71
122.	Disable Code 128	00690	02 02 06 82 30 30 36 39 30 00 00 00 00 03 72
123.	Enable Code 39	00221	02 02 06 82 30 30 32 32 31 00 00 00 00 03 7C
124.	Disable Code 39	00220	02 02 06 82 30 30 32 32 30 00 00 00 00 03 7D
125.	Code 39 send ending/start character	00281	02 02 06 82 30 30 32 38 31 00 00 00 00 03 76
126.	Code 39 don't send ending/start character	00280	02 02 06 82 30 30 32 38 30 00 00 00 00 03 77
127.	Code 39 enable Full ASCII	00231	02 02 06 82 30 30 32 33 31 00 00 00 00 03 7B
128.	Code 39 disable Full ASCII	00230	02 02 06 82 30 30 32 33 30 00 00 00 00 03 7C
129.	Enable Code 93	00621	02 02 06 82 30 30 36 32 31 00 00 00 00 03 78
130.	Disable Code 93	00620	02 02 06 82 30 30 36 32 30 00 00 00 00 03 79
131.	Send code 93 check bit	01901	02 02 06 82 30 31 39 30 31 00 00 00 00 03 76
132.	Don't send code 93 check bit	01900	02 02 06 82 30 31 39 30 30 00 00 00 00 03 77
133.	Enable Code 11	01261	02 02 06 82 30 31 32 36 31 00 00 00 00 03 77
134.	Disable Code 11	01260	02 02 06 82 30 31 32 36 30 00 00 00 00 03 78
135.	Code 11 C check	01272	02 02 06 82 30 31 32 37 32 00 00 00 00 03 75
136.	Code 11 CK check	01273	02 02 06 82 30 31 32 37 33 00 00 00 00 03 74
137.	Code 11 auto CK check	01271	02 02 06 82 30 31 32 37 31 00 00 00 00 03 76
138.	Enable Interleaved 2 of 5	00961	02 02 06 82 30 30 39 36 31 00 00 00 00 03 71
139.	Disable Interleaved 2 of 5	00960	02 02 06 82 30 30 39 36 30 00 00 00 00 03 72
140.	Enable Matrix 2 of 5	01461	02 02 06 82 30 31 34 36 31 00 00 00 00 03 75
141.	Disable Matrix 2 of 5	01460	02 02 06 82 30 31 34 36 30 00 00 00 00 03 76
142.	Enable Industrial 2 of 5	01061	02 02 06 82 30 31 30 36 31 00 00 00 00 03 79
143.	Disable Industrial 2 of 5	01060	02 02 06 82 30 31 30 36 30 00 00 00 00 03 7A

144.	Enable	Standard 2 of 5	01871	02 02 06 82 30 31 38 37 31 00 00 00 00 00 03 70
145.	Disable	Standard 2 of 5	01870	02 02 06 82 30 31 38 37 30 00 00 00 00 00 03 71
146.	Enable	Codabar	00851	02 02 06 82 30 30 38 35 31 00 00 00 00 00 03 73
147.	Disable	Codabar	00850	02 02 06 82 30 30 38 35 30 00 00 00 00 00 03 74
148.	Codabar send ending/start character		00861	02 02 06 82 30 30 38 36 31 00 00 00 00 00 03 72
149.	Codabar don't send ending/start character		00860	02 02 06 82 30 30 38 36 30 00 00 00 00 00 03 73
150.	Enable	Plessey	01161	02 02 06 82 30 31 31 36 31 00 00 00 00 00 03 78
151.	Disable	Plessey	01160	02 02 06 82 30 31 31 36 30 00 00 00 00 00 03 79
152.	Enable	MSI Plessey	01151	02 02 06 82 30 31 31 35 31 00 00 00 00 00 03 79
153.	Disable	MSI Plessey	01150	02 02 06 82 30 31 31 35 30 00 00 00 00 00 03 7A
154.	Enable	RSS Limited	01771	02 02 06 82 30 31 37 37 31 00 00 00 00 00 03 71
155.	Disable	RSS Limited	01770	02 02 06 82 30 31 37 37 30 00 00 00 00 00 03 72
156.	Enable	RSS Omni	01671	02 02 06 82 30 31 36 37 31 00 00 00 00 00 03 72
157.	Disable	RSS Omni	01670	02 02 06 82 30 31 36 37 30 00 00 00 00 00 03 73
158.	Enable	China Post	01571	02 02 06 82 30 31 35 37 31 00 00 00 00 00 03 73
159.	Disable	China Post	01570	02 02 06 82 30 31 35 37 30 00 00 00 00 00 03 74
160.	Enable	2 additional bits	00551	02 02 06 82 30 30 35 35 31 00 00 00 00 00 03 76
161.	Enable	5 additional bits	00552	02 02 06 82 30 30 35 35 32 00 00 00 00 00 03 75
162.	Enable	2 and 5 additional bits	00553	02 02 06 82 30 30 35 35 33 00 00 00 00 00 03 74
163.	Disable	additional bits	00550	02 02 06 82 30 30 35 35 30 00 00 00 00 00 03 77
164.	Forced to include additional bits		02611	02 02 06 82 30 32 36 31 31 00 00 00 00 00 03 77
165.	Do not force include additional bits		02610	02 02 06 82 30 32 36 31 30 00 00 00 00 00 03 78
166.	Enable response		02421	02 02 06 82 30 32 34 32 31 00 00 00 00 00 03 78

167.	Disable response	02420	02 02 06 82 30 32 34 32 30 00 00 00 00 00 03 79
168.	Enable sound response	01411	02 02 06 82 30 31 34 31 31 00 00 00 00 00 03 7A
169.	Disable sound response	01410	02 02 06 82 30 31 34 31 30 00 00 00 00 00 03 7B
170.			02 01 03 AA 55 00 00 00 00 00 00 00 00 00 03 F8

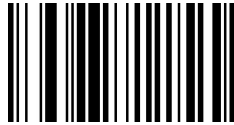
**Appendix 3 - Character Table (for adding suffixes and prefix)**

1001

SOH (01)

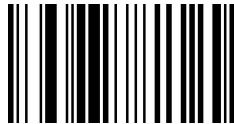

1004

EOT (04)



1007

BEL (07)



1010

LF (0A)



1013

CR (0D)



1016

DEL (10)



1019

DC3 (13)



1022



1002

STX (02)

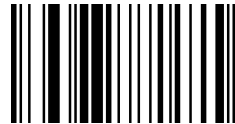

1005

ENQ (05)



1008

Backspace (08)



1011

VT (0B)



1014

SO (0E)



1017

DC1 (11)



1020

DC4 (14)



1023

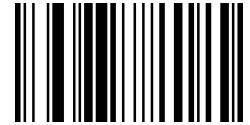

1003

ETX (03)

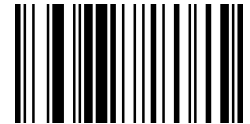

1006

ACK (06)

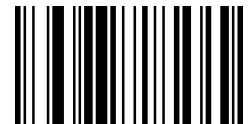

1009

HT (09)

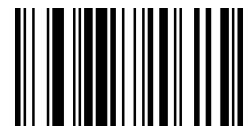

1012

FF (0C)



1015

SI (0F)



1018

DC2 (12)



1021

NAK (15)



1024



SYN (16)



1025

EM (19)



1028

FS (1C)

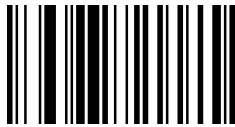

1031

US (1F)

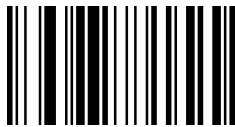

1034

“ (22)



1037

% (25)

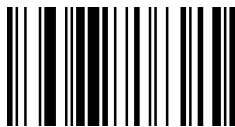

1040

( (28)



1043

+ (2B)

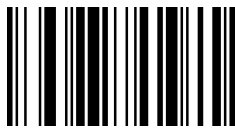

1046

. (2E)

ETB (17)

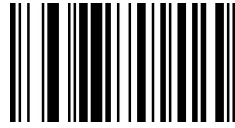

1026

SUB (1A)

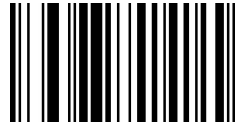

1029

GS (1D)

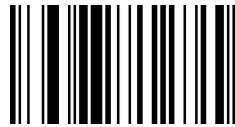

1032

Space (20)



1035

# (23)

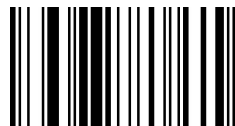

1038

& (26)

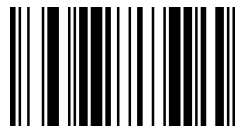

1041

) (29)



1044

, (2C)

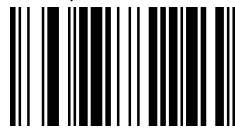

1047

/ (2F)

CAN (18)



1027

ESC (1B)



1030

RS (1E)

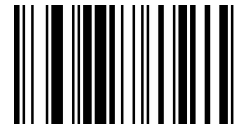

1033

! (21)



1036

\$ (24)



1039

‘ (27)

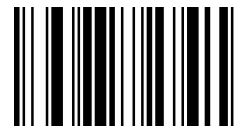

1042

\* (2A)



1045

- (2D)



1048

0 (30)



1049

1 (31)



1052

4 (34)



1055

7 (37)

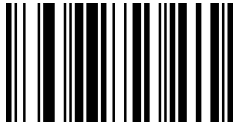

1058

: (3A)

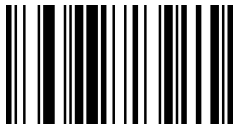

1061

= (3D)

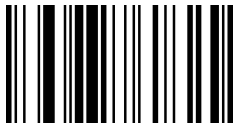

1064

@ (40)



1067

C (43)

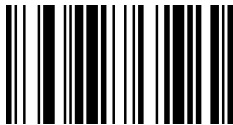

1070

F (46)



1050

2 (32)



1053

5 (35)

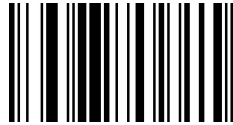

1056

8 (38)

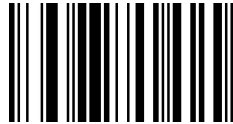

1059

; (3B)

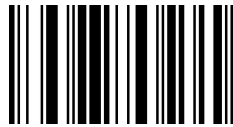

1062

> (3E)

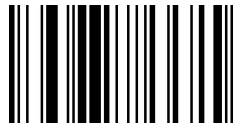

1065

A (41)

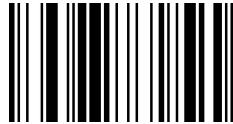

1068

D (44)

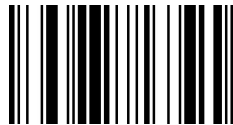

1071

G (47)



1051

3 (33)



1054

6 (36)

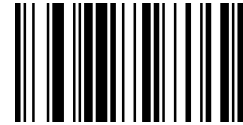

1057

9 (39)



1060

< (3C)



1063

? (3F)

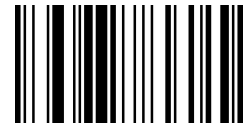

1066

B (42)



1069

E (45)

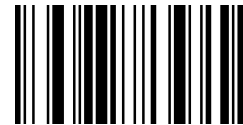

1072

H (48)

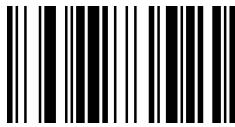

1073  
I (49)



1076  
L (4C)

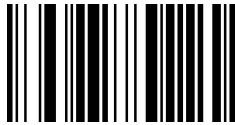

1079  
O (4F)

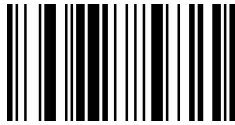

1082  
R (52)

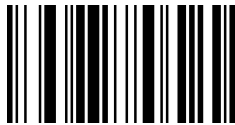

1085  
U (55)

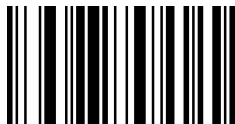

1088  
X (58)

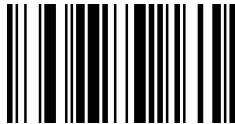

1091  
[ (5B)

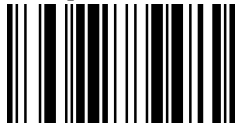

1094  
^ (5E)

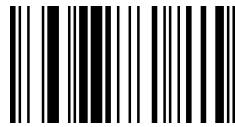

1074  
J (4A)

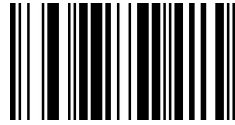

1077  
M (4D)



1080  
P (50)

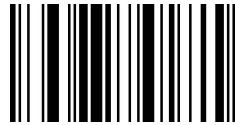

1083  
S (53)

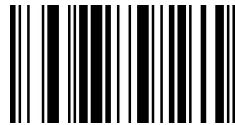

1086  
V (56)

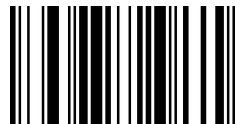

1089  
Y (59)

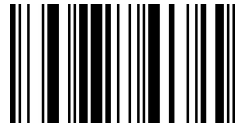

1092  
\ (5C)



1095  
\_ (5F)

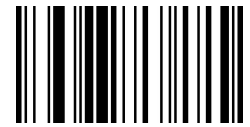

1075  
K (4B)

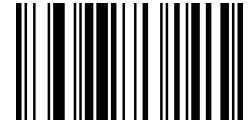

1078  
N (4E)



1081  
Q (51)



1084  
T (54)

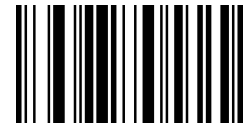

1087  
W (57)

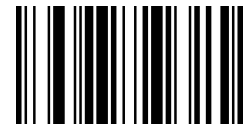

1090  
Z (5A)

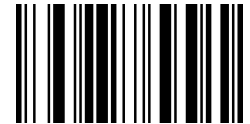

1093  
) (5D)

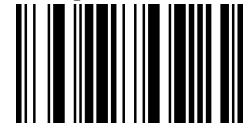

1096  
` (60)



1097  
1121  
a (61)



1098  
1122  
b (62)



1099  
1123  
c (63)



1100  
1124  
d (64)



1101  
1125  
e (65)



1102  
1126  
f (66)



1103  
1127  
g (67)  
Delete (7F)



1104  
h (68)



1105  
i (69)



1106  
j (6A)



107  
k (6B)



1108  
l (6C)



1109  
m (6D)



1110  
n (6E)



1111  
o (6F)



1112  
p (70)



1113  
q (71)



1114  
r (72)



1115  
s (73)



1116  
t (74)



1117  
u (75)



1118  
v (76)



1119  
w (77)



1120  
x (78)



1115  
s (73)



1116  
t (74)



1117  
u (75)



1118  
v (76)



1119  
w (77)



1120  
x (78)

**Appendix 4 - ASCII Code Table**

Hexadecimal	ASCII value	character
00	00	NUL (Null char.)
01	01	SOH (Start of Header)
02	02	STX (Start of Text)
03	03	ETX (End of Text)
04	04	EOT (End of Transmission)
05	05	ENQ (Enquiry)
06	06	ACK (Acknowledgment)
07	07	BEL (Bell)
08	08	BS (Backspace)
09	09	HT (Horizontal Tab)
0A	10	LF (Line Feed)
0B	11	VT (Vertical Tab)
0C	12	FF (Form Feed)
0D	13	CR (Carriage Return)
0E	14	SO (Shift Out)
0F	15	SI (Shift In)
10	16	DLE (Data Link Escape)
11	17	DC1 (XON) (Device Control 1)
12	18	DC2 (Device Control 2)
13	19	DC3 (XOFF) (Device Control 3)
14	20	DC4 (Device Control 4)
15	21	NAK (Negative Acknowledgment)
16	22	SYN (Synchronous Idle)
17	23	ETB (End of Trans. Block)
18	24	CAN (Cancel)
19	25	EM (End of Medium)
1A	26	SUB (Substitute)
1B	27	ESC (Escape)
1C	28	FS (File Separator)
1D	29	GS (Group Separator)
1E	30	RS (Request to Send)
1F	31	US (Unit Separator)
20	32	SP (Space)
21	33	! (Exclamation Mark)
22	34	" (Double Quote)
23	35	# (Number Sign)
24	36	\$ (Dollar Sign)
25	37	% (Percent)
26	38	& (Ampersand)
27	39	` (Single Quote)

28	40	( (Right / Closing Parenthesis)
29	41	) (Right / Closing Parenthesis)
2A	42	* (Asterisk)
2B	43	+ (Plus)
2C	44	, (Comma)
2D	45	- (Minus / Dash)
2E	46	. (Dot)
2F	47	/ (Forward Slash)
30	48	0
31	49	1
32	50	2
33	51	3
34	52	4
35	53	5
36	54	6
37	55	7
38	56	8
39	57	9
3A	58	: (Colon)
3B	59	; (Semi-colon)
3C	60	< (Less Than)
3D	61	= (Equal Sign)
3E	62	> (Greater Than)
3F	63	? (Question Mark)
40	64	@ (AT Symbol)
41	65	A
42	66	B
43	67	C
44	68	D
45	69	E
46	70	F
47	71	G
48	72	H
49	73	I
4A	74	J
4B	75	K
4C	76	L
4D	77	M
4E	78	N
4F	79	O
50	80	P
51	81	Q
52	82	R

53	83	S
54	84	T
55	85	U
56	86	V
57	87	W
58	88	X
59	89	Y
5A	90	Z
5B	91	[ (Left / Opening Bracket)
5C	92	\ (Back Slash)
5D	93	] (Right / Closing Bracket)
5E	94	^ (Caret / Circumflex)
5F	95	_ (Underscore)
60	96	' (Grave Accent)
61	97	A
62	98	B
63	99	C
64	100	d
65	101	e
66	102	f
67	103	g
68	104	h
69	105	i
6A	106	j
6B	107	k
6C	108	l
6D	109	m
6E	110	n
6F	111	o
70	112	p
71	113	q
72	114	r
73	115	s
74	116	t
75	117	u
76	118	v
77	119	w
78	120	x
79	121	y
7A	122	z
7B	123	{ (Left/ Opening Brace)
7C	124	(Vertical Bar)

7D	125	} (Right/Closing Brace)
7E	126	~ (Tilde)
7F	127	DEL (Delete)

